



ROBOTIC DEVICE FOR CHINESE SHADOW PUPPETRY

Inventor: Bai Jiaxu, Chen Ying

Included in Education Digest

ISSN: ISSN1009-7406

Periodical number: 11-5773/G4

National patent application No.: ZL201820698272.7

01 Background of Invention



- China is of a long history, and there is rare display of traditional culture in the life. Due to the impact of modern film and television art, the audience and performance market are decreasing, and there are fewer traditional artists performing shadow puppetry. The shadow puppetry is facing the danger of extinction and needs to be rescued and protected urgently. The robotic device for Chinese shadow puppetry replaces the manually operated shadow puppet with the robot. The upper part of robotic device uses the connecting rod to control the movement range of shadow puppet, and the lower part uses the light sensor to depict the action track of shadow puppet.
- The existing shadow puppetry device cannot perform the shadow puppetry automatically.
- Therefore, there is the robotic device for Chinese shadow puppetry.

02 Disadvantages of Prior Art and Improvement of New Invention



Disadvantages of Prior Art

China is of a long history, and there is rare display of traditional culture in the life. Due to the impact of modern film and television art, the audience and performance market are decreasing, and there are fewer traditional artists performing shadow puppetry. The shadow puppetry is facing the danger of extinction and needs to be rescued and protected urgently. The existing shadow puppetry device cannot perform the shadow puppetry automatically.



Improvement of New Invention

The robotic device for Chinese shadow puppetry replaces the manually operated shadow puppet with the robot. The upper part of robotic device uses the connecting rod to control the movement range of shadow puppet, and the lower part uses the light sensor to depict the action track of shadow puppet. It can perform the shadow puppetry automatically.



03 New Technical Advantages of This Invention



The stability of rotation of shadow puppetry model can be greatly guaranteed by setting the structure, so as to prevent the inflexible rotation due to the large action range of shadow puppetry model during performance of shadow puppetry, and improve the shadow puppetry performance well.



The robot is provided with the car body, which is provided with the motor to drive the rotation of wheels through the action of gears. Furthermore, it is also provided with the light sensor, which can detect the movement position of this device by detecting the change of light, so as to ensure that this device will not cause performance errors due to the wrong placement position during movement on the stage. Moreover, the offset caused by the device marching or moving on the stage can be detected by the light sensor, and it can drive the device to reset.



The robot can be used to perform the shadow puppetry automatically, and store the items that are easy to be lost completely for a long time, such as action and music of shadow puppetry.

04 Research Results and Application Management

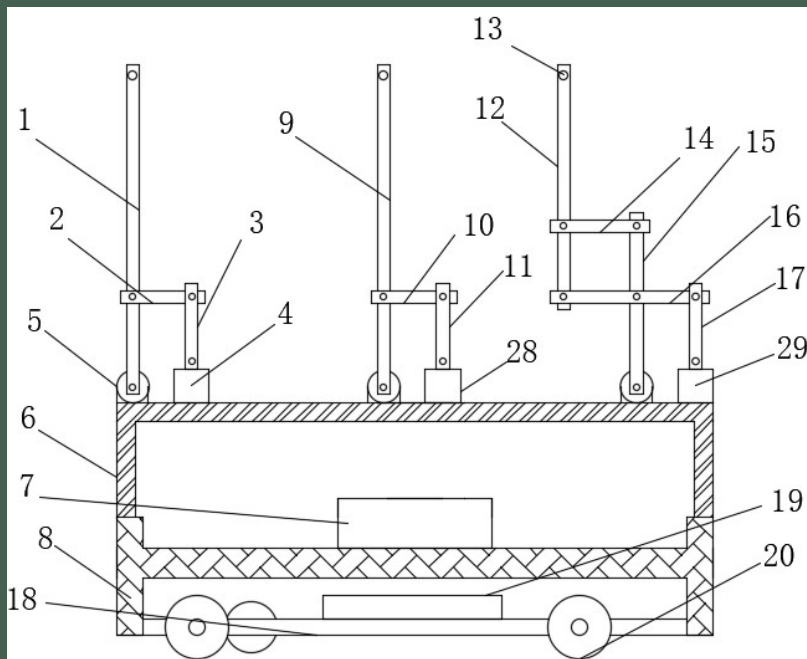

- China is of a long history, and there is rare display of traditional culture in the life. Due to the impact of modern film and television art, the audience and performance market are decreasing, and there are fewer traditional artists performing shadow puppetry. The shadow puppetry is facing the danger of extinction and needs to be rescued and protected urgently. The robotic device for Chinese shadow puppetry replaces the manually operated shadow puppet with the robot. The upper part of robotic device uses the connecting rod to control the movement range of shadow puppet, and the lower part uses the light sensor to depict the action track of shadow puppet.
- I believe that my robotic device for Chinese shadow puppetry can inherit and carry forward the Chinese traditional culture in the era of artificial intelligence.

Thanks!

With the continuous development of China's economy, the Chinese culture is also taking off rapidly. I observe a group of inheritors adhere to the China's beautiful traditional culture in the fast-paced life during development.

China is of a long history, and there is rare display of traditional culture in the life. Due to the impact of modern film and television art, the audience and performance market are decreasing, and there are fewer traditional artists performing shadow puppetry. The shadow puppetry is facing the danger of extinction and needs to be rescued and protected urgently. I hope that the beauty of China can be seen worldwide through my works.

I would like to thank all judges for their patient watching and listening!

